

Termination Insensitive Feedback Amp Gain Selection

RL	RF	RD	Gain
330	270	27	7.2dB
330	390	22	10.8dB
330	510	18	13.4dB
330	680	15	15.7dB
330	1000	10	19.3dB
330	1800	4r7	24.3dB
470	620	20	15.1dB
470	1500	10	22.6dB

TIA - Termination Insensitive I.F. Amplifier. Based on Wes Hayward's (W7ZOI) and Bob Kopski's (K3NHI) white paper entitled: 'A Termination Insensitive Amplifier for Bidirectional Transceivers'

http://w7zoi.net/bidirectional_matched_amplifier.pdf

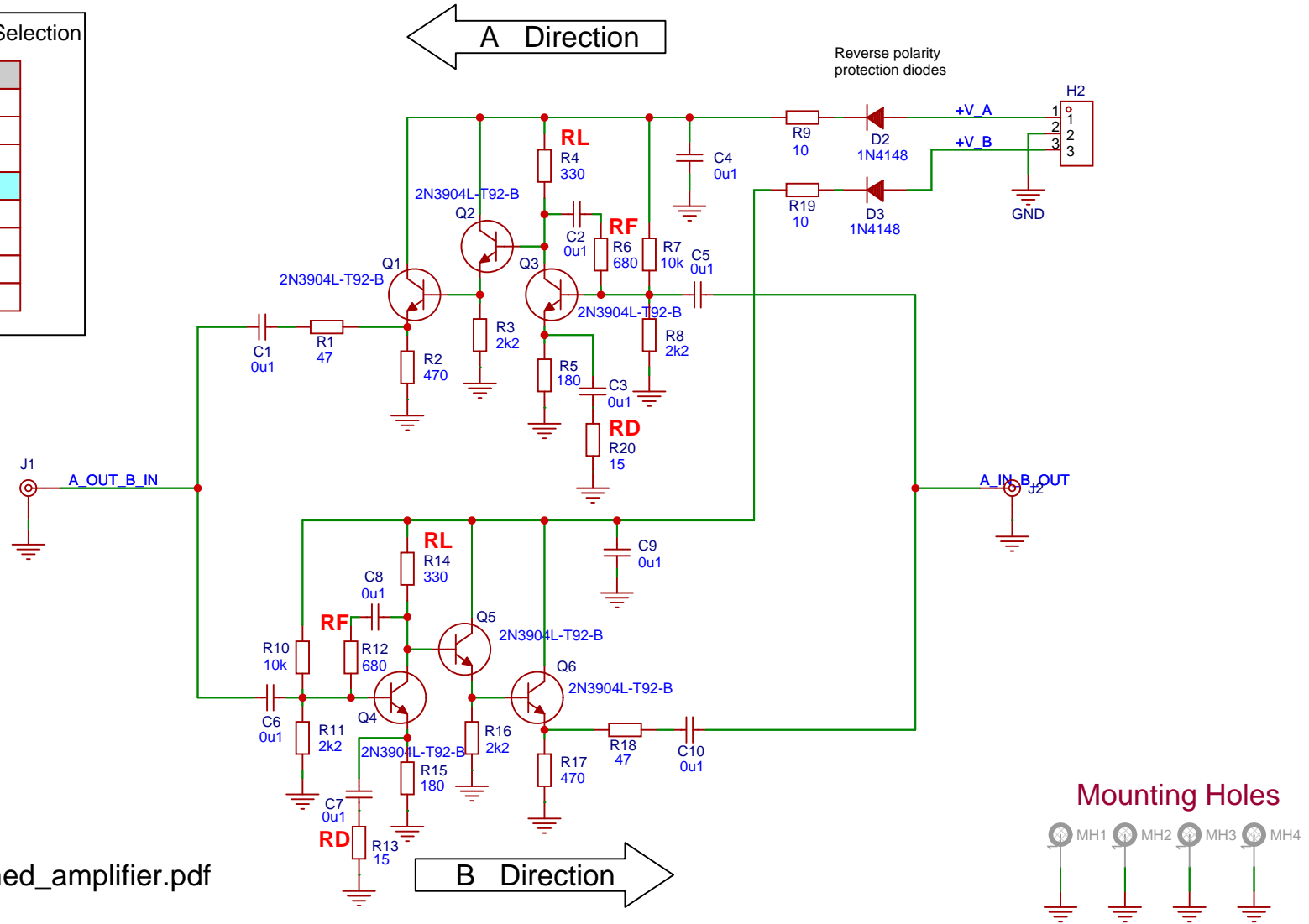

Schematic	Schematic1			Create at	2026-01-29
Board	Board1			Update at	2026-01-31
Drawn				Page	P1
Reviewed				MAX-SSB_(210)_IF_AMP_A	
	Version	Size	Page 1 Total 1		
		V1.0	A4	EasyEDA.com	